

LOCTITE

1001 Trout Brook Crossing
Rocky Hill, CT 06067-3910
Telephone: (860) 571-5100
FAX: (860) 571-5465

Product Description Sheet Hysol® 175-SPRAY Hot Melt Applicator

Part # 98037

North American Equipment, August 2001

PRODUCT DESCRIPTION

Loctite® Hysol® 175-SPRAY Hot Melt Applicator is a high output hand-held, electro-pneumatic hot melt applicator. The product is ergonomically designed to heat, melt and dispense all Loctite Hysol structural hot melt products. The 175-SPRAY Applicator is designed for high volume spray applications, high production industrial environments.

PRODUCT FEATURES

- Designed for operator comfort and application control
- Low actuation force to reduce finger fatigue
- Fixed precision operating temperature, 180°C
- Heater: (2) 250 Watt Stainless Steel Cartridges
- 1 3/4" Polyshot EVA loading
- Variable Narrow to Ultra Wide dispense patterns
- Dispenses up to 8.0 pounds per hour
- Weight: 4.0 pounds

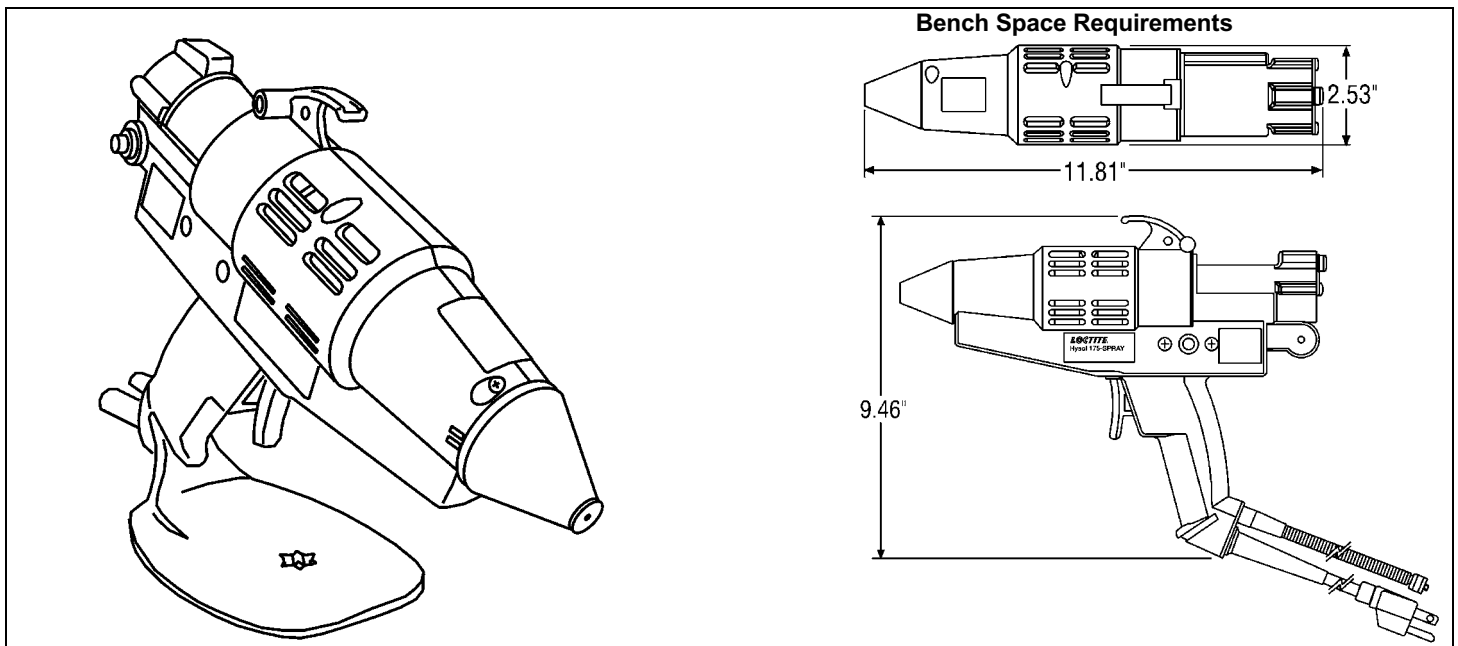

Technical Data

- Utilities: 110/120 VAC, 50/60 Hz,
- Air Supply 45 psi minimum 100 psi maximum
- Heat-up time: 5 to 7 minutes
- Heater: (2) 250 Watt Cartridges

Hot Melt Applicator P/N 98037 includes:

- Instruction manual - P/N 985119
- Hysol 175-SPRAY Hot Melt Cartridge Dispenser
- Dispenser Stand - P/N 985069
- Valve Body Air Line Adapter - P/N 985240
-

Optional Accessories

- Replacement standard wide spray nozzle - P/N 985122
- Narrow spray nozzle - P/N 985211
- Ultra-wide spray nozzle - P/N 985216
- Tool Hanger/Balancer - P/N 985243
- Heavy-duty metal stand - P/N 985087

NOT FOR PRODUCT SPECIFICATIONS
PLEASE CONTACT LOCTITE CORPORATION FOR ASSISTANCE: 1-800-LOCTITE (1-800-562-8483)

The data contained herein are furnished for information only and are believed to be reliable. We cannot assume responsibility for the results obtained by others over whose methods we have no control. It is the user's responsibility to determine suitability for the user's purpose of any production methods mentioned herein and to adopt such precautions as may be advisable for the protection of property and of persons against any hazards that may be involved in the handling and use thereof. In light of the foregoing, LOCTITE CORPORATION SPECIFICALLY DISCLAIMS ALL WARRANTIES EXPRESSED OR IMPLIED, INCLUDING WARRANTIES OF MERCHANTABILITY OR FITNESS FOR A PARTICULAR PURPOSE, ARISING FROM SALE OR USE OF LOCTITE CORPORATION'S PRODUCTS. LOCTITE CORPORATION SPECIFICALLY DISCLAIMS ANY LIABILITY FOR CONSEQUENTIAL OR INCIDENTAL DAMAGES OF ANY KIND, INCLUDING LOST PROFITS. The discussion herein of various processes or compositions is not to be interpreted as representation that they are free from domination of patents owned by others or as a license under any Loctite Corporation patents that may cover such processes or compositions. We recommend that each prospective user test his proposed application before repetitive use, using this data as a guide. This product may be covered by one or more United States or foreign patents or patent applications.

Loctite and Hysol are trademarks of Loctite Corp. U.S.A.