

# LOCTITE

1001 Trout Brook Crossing  
Rocky Hill, CT 06067-3910  
Telephone: (860) 571-5100  
FAX: (860) 571-5465

## Product Description Sheet Hysol® 075 Hot Melt Applicator

Part # 98033

North American Equipment, August 2001

### PRODUCT DESCRIPTION

Loctite® Hysol® 075 Hot Melt Applicator is a hand-held, electric, hot melt adhesive applicator. The product is ergonomically designed to heat, melt and dispense all 3/4" Loctite Hysol structural hot melt products. The 075 Hot Melt Applicator is designed for high volume, high production industrial environments.

### PRODUCT FEATURES

- Light weight, well balanced and ergonomically designed for operator comfort and application control
- Low actuation force to reduce finger fatigue
- Electronic temperature control
- Fixed precision temperature: 360°F (182°C)
- Dispenses up to 9.0 pounds per hour
- Single 3/4"x 2 1/2" Maxistick loading

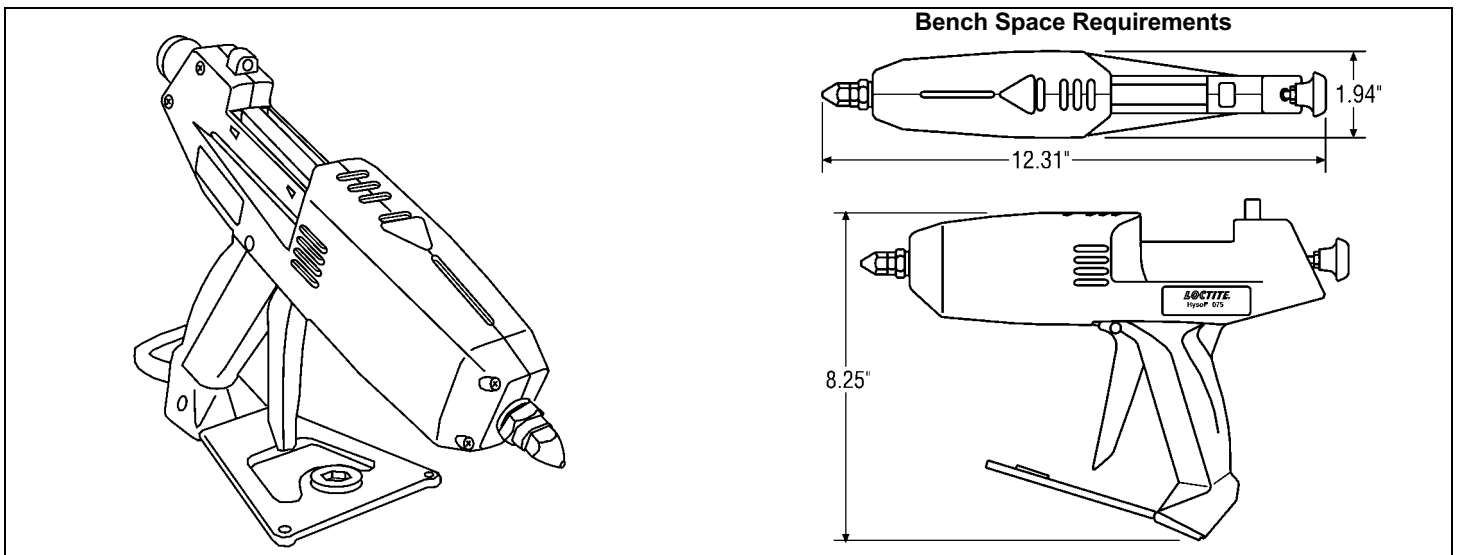

### Technical Data

- Utilities: 120 VAC, 50/60 Hz, single phase
- Heat-up time: 7 to 10 minutes
- Heater: (2)200 Watt Cartridges
- Weight: 1.6 pounds (862 grams)

### Hot Melt Applicator P/N 98033 includes:

- Instruction manual - P/N 985315
- Hysol 075 Hot Melt Stick Applicator
- Dispenser Stand - P/N ISZ002
- Speed Loader - P/N IZZ020
- Standoff Wings (2) - P/N ISZ005

### Optional Accessories

- Replacement standard nozzle, .06"DIA cone tip - P/N 985225
- 2-hole nozzle - P/N 985110
- 3-hole nozzle - P/N 985111
- Extension nozzle, .14"DIA x 1.23"LG - P/N 985112
- Needle extension nozzle, .05"DIA x 1.32"LG - P/N 985113
- Spreader extension nozzle, (.09".25"SQ) x 1.22"LG - P/N 985114
- "L" Nozzle (ideal for overlap carton sealing) - P/N 985115
- Replacement adapter/check-valve for nozzles - P/N 985088
- T-nozzle (ideal for center-flap carton sealing) - P/N 985116
- Tool Hanger/Balancer - P/N 985243

NOT FOR PRODUCT SPECIFICATIONS  
PLEASE CONTACT LOCTITE CORPORATION FOR ASSISTANCE: 1-800-LOCTITE (1-800-562-8483)

The data contained herein are furnished for information only and are believed to be reliable. We cannot assume responsibility for the results obtained by others over whose methods we have no control. It is the user's responsibility to determine suitability for the user's purpose of any production methods mentioned herein and to adopt such precautions as may be advisable for the protection of property and of persons against any hazards that may be involved in the handling and use thereof. In light of the foregoing, LOCTITE CORPORATION SPECIFICALLY DISCLAIMS ALL WARRANTIES EXPRESSED OR IMPLIED, INCLUDING WARRANTIES OF MERCHANTABILITY OR FITNESS FOR A PARTICULAR PURPOSE, ARISING FROM SALE OR USE OF LOCTITE CORPORATION'S PRODUCTS. LOCTITE CORPORATION SPECIFICALLY DISCLAIMS ANY LIABILITY FOR CONSEQUENTIAL OR INCIDENTAL DAMAGES OF ANY KIND, INCLUDING LOST PROFITS. The discussion herein of various processes or compositions is not to be interpreted as representation that they are free from domination of patents owned by others or as a license under any Loctite Corporation patents that may cover such processes or compositions. We recommend that each prospective user test his proposed application before repetitive use, using this data as a guide. This product may be covered by one or more United States or foreign patents or patent applications.

Loctite and Hysol are trademarks of Loctite Corp. U.S.A.